

Trade Mark:
CRYSTAL WORLD INC

Product Name: Pendant lamp
Model :8001C10
120Vac, 60Hz,AC ONLY
Lamp Size:φ10"*H7"

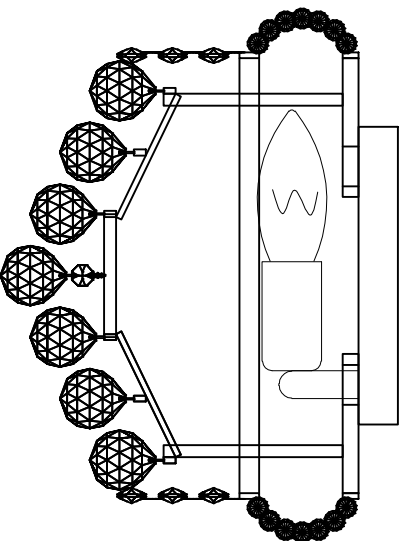

Intertek
4006677

PENDANT LAMP ASSEMBLY INSTRUCTIONS

1. Please take off the plastic sheet from the lamp body.
2. Please wear gloves when you hanging the crystal.
3. Install bulbs (NOT INCLUDED).USE 120V E12  3* 40W Max.

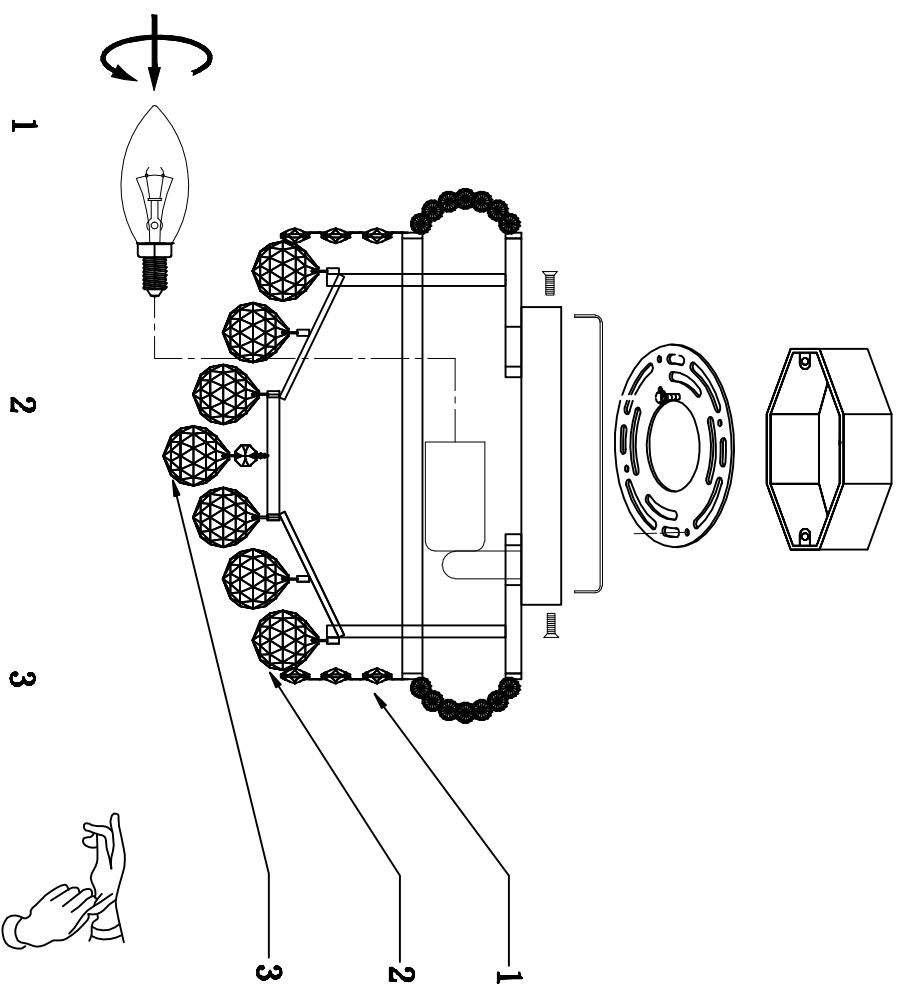

1
14mm*3pcs

2
30mm*1pcs

3
12mm*1pcs
30mm*1pcs

42PCS

36PCS

1PCS